

BRINGING **IDEAS** TO LIFE

Our approach to delivering a digital signage solution to your **retail** environment.

*E-Paper
Shelf Edge Displays*







DIGITAL SIGNAGE INCREASES RETAIL SALES

200%

INCREASE
AUDIENCE
RETENTION
RATE

63%

MORE PEOPLE
SAY THAT DIGITAL
SIGNAGE
CATCHES
THEIR EYE

30%

INCREASE
SALES
WHEN USING
DIGITAL SIGNAGE

26%

INCREASE FOOTFALL
DUE TO DIGITAL
SIGNAGE
INSTALLATIONS
AT RETAIL STORES

60%

BUYING DECISIONS
ARE MADE AT
POINT OF SALE

-TABLE OF CONTENTS-

WHAT IS AN ELECTRONIC SHELF LABEL (ESL)?	6
BENEFITS OF AN ESL	8
HARDWARE	10
SOFTWARE	12
ACCESSORIES	14
EXAMPLES	16
TECHNICAL SPECIFICATIONS	18

WHAT IS AN ELECTRONIC SHELF LABEL (ESL)?





-WHAT IS AN ELECTRONIC SHELF LABEL (ESL)?-

Electronic shelf label systems are used to display and automatically update product pricing shown on shelves. They are typically comprised of three components:

- Label management software
- Communication controllers
- E-paper display modules

The label management software provides an intuitive way for users to easily manage pricing and stock information for every product across their entire network of stores. This information is then sent to the communication controller via Wi-Fi before being transmitted to the e-paper display modules via a private 2.G Wi-Fi signal for ultimate data transfer security. Updates are automatically rolled out across the shop floor instantly.

HOW ESLs WORK:

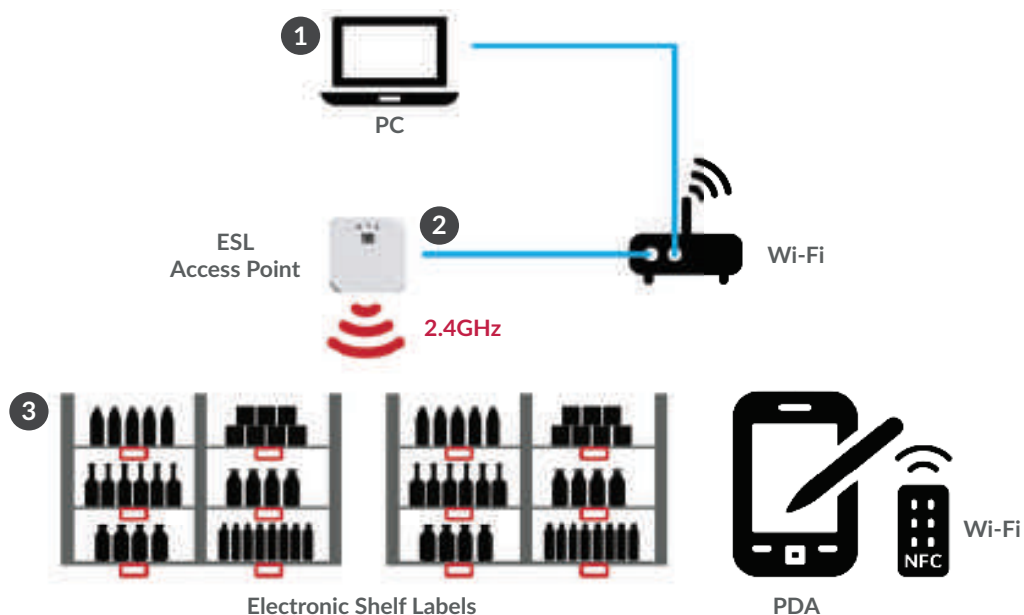

BENEFITS OF AN ESL





-BENEFITS OF AN ESL-

- Improve ease and efficiency of pricing management
- Enhance customers' in-store shopping experience
- Instantly deliver time-limited promotions and dynamic price changes across every store
- Optimise store layout based on real data
- Reduce losses of short shelf-life products
- Reduce labour costs and save human resources for more important tasks
- React quickly to competitor/market changes
- Enable quick and easy navigation to specific products
- Reduce processing time for online orders
- Improve sustainability by reducing paper and food waste

WHY CHOOSE US?

- 13 Years of Digital Signage Expertise
- Outstanding Customer Service
- High Quality Products with Commercial Grade Components
- Queen's Award for Enterprise in Innovation
- Lifetime Tech Support & 3-Year Manufacturer's Warranty

HARDWARE



- HARDWARE -

WIDE RANGE OF SOLUTIONS

From supermarkets to clothes stores to canteens and everything in between, these displays are available in a wide range of shapes and sizes to suit any industry sector. There is even an IP67-rated waterproof version for applications such as seafood tanks, and a frost-proof version that can operate at temperatures as low as -25°C for use in freezers.

TRI-COLOUR E-PAPER DISPLAYS

Utilising e-paper technology, these durable displays have an ultra-wide viewing angle and extremely low power consumption. Plus, with three colour options available for content (black/white/yellow or black/white/red), you can add eye-catching colour to your shelf labels.

5-YEAR SINGLE CHARGE BATTERY

Thanks to the ultra-long battery life and automatic power allocation, these displays can be in 24/7 use for up to 5 years on a single charge (based on 4 updates per day).

ROBUST ENCLOSURE

These displays are designed for commercial use in public spaces and the outer casing is no exception, made of a sturdy hard-wearing plastic. This also available in a range of custom colours to match your branding.

MULTI-COURED LED LIGHT

Able to flash in 7 different colours, the built-in LED light helps staff to navigate to specific ESL locations quickly, such as when picking products to fulfil online orders or when identifying items that are out-of-stock.

ANTI-THEFT INSTALLATION

For maximum security against potential theft, a specialised tool is required to remove ESLs from shelves.

RANGE OF SIZES:

Small ESLs



Medium ESLs



Large ESLs



SOFTWARE



- SOFTWARE -

AUTOMATIC PRICING UPDATES

Automatically update the pricing of your whole product range across an entire network of stores from one centralised location, helping you to save on manual labour costs and ensuring total price accuracy.

MULTIPLE PAGES

Each display can have up to 7 different pages, giving you the flexibility to show more than just price. For instance, choose between showing standard pricing, promotions, out-of-stock notices, interactive QR codes, real-time stock inventory, order status and more. Staff can then easily switch between these pages using PDA devices.

CLOUD MONITORING SYSTEM

Continuous data reporting allows users to improve operation efficiency and monitor device performance, as well as receiving real-time alerts when abnormalities are detected to eliminate pricing errors.

INTEGRATED NFC

Thanks to the integrated NFC functionality, both staff and customers can interact with the ESLs using smartphones and PDA devices.

OVER-THE-AIR FIRMWARE UPDATES

The system can be updated remotely without the need for a physical recall, meaning new software features can be added and bugs can be fixed swiftly.

RAPID UPDATE SPEED

With an incredible update speed of up to 18,000 ESLs per hour, pricing updates can be rolled out rapidly. This enables much more dynamic pricing strategies and promotions, reducing food waste and ensuring you can react quickly to competitor/market changes.

ACCURATE LOCATION FINDING

Pinpoint exactly where each ESL label is located with 95% accuracy to aid product navigation for both staff and customers, enabling you to increase the efficiency of product picking for online orders and enhance the customer experience by improving wayfinding.

PDA APP AVAILABLE

As the system is compatible with all major PDA brands, staff can easily use these devices to perform functions such as binding/unbinding ESLs with products, switching pages on the ESL display, and more.

INTEGRATE WITH EXISTING SYSTEMS

The ESL system can be seamlessly integrated with existing stock management systems via an API for minimal disruption to your digital infrastructure.

STREAMLINE PRICE CHANGE PROCESSES with state of the art automated digital shelf edge solution



ACCESSORIES



- ACCESSORIES -

INSTALLATION

Various fixing options, such as...



Stand



Rail



Clamp



Ice stick



Bracket



Hanging



Hook



Strike-resistant protective shell

Protects ESL displays from potential damage



End cap

Fitted to rail ends to protect customers by covering sharp edges



Wedged block

Tilts rail to optimum viewing angle



ESL driver

A specialised tool used to remove ESL modules from shelves

IN-STORE MARKETING



PROMOTION CARDS

Customisable, durable plastic cards that can be attached to ESL modules to draw attention to particular products and promotions

EXAMPLES





ELECTRONIC SHELF LABEL **TECHNICAL SPECIFICATION**



-ESL-G-TYPE 1.5"-

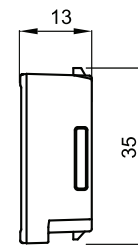
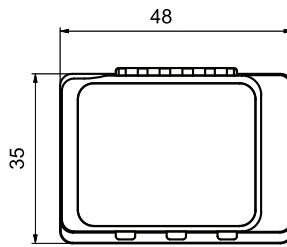

	1.5"	
Unit Size (WxHxD mm)	48x35x13	
Display Area (mm)	27x27	
Resolution	200x200	
Net Weight (g)	21.7	
Case Colour	White or customised	
DPI	188	
Display Colour	BWR, BWY	
NFC	<p>"N" means the ESL with NFC function.</p> <ol style="list-style-type: none"> 1. Complies with ISO/IEC 14443 TypeA standard 2. Supports NFC NDEF data format with 200 bytes writable memory 3. Communication distance is reachable maximum 10mm 4. Batch update of the same template 	
Multiple Pages	4 Pages	
LED Flash	Red, Blue, Green	
Working Life	3 Years (4 Updates per day)	
Battery	1x550mAh	
Changeable Battery	Battery Pack	
Operating Temperature	0 °C to 30 °C	
Operating Humidity	30% to 70%	
Protection Level	IP54	
Certification	ROHS, CE, FCC, MIC	
RF Wireless Communication Parameters	Working Frequency: 2402Mhz to 2480Mhz	System Throughput: Up to 18,000 labels per hour
Included Accessories	TBC	
Optional Accessories	TBC	
Warranty Period	3 Year Warranty	
Technical Support	Lifetime	

-ESL-G-TYPE 2.1"-

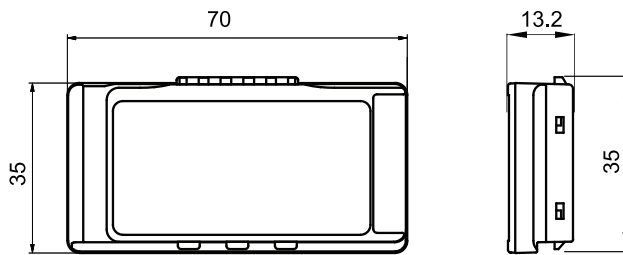

	2.1"	
Unit Size (WxHxD mm)	70x35x13.2	
Display Area (mm)	48.6x23.7	
Resolution	250x122	
Net Weight (g)	36	
Case Colour	White or customised	
DPI	131	
Display Colour	BWR, BWY	
NFC	<p>"N" means the ESL with NFC function.</p> <ol style="list-style-type: none"> 1. Complies with ISO/IEC 14443 TypeA standard 2. Supports NFC NDEF data format with 200 bytes writable memory 3. Communication distance is reachable maximum 10mm 4. Batch update of the same template 	
Multiple Pages	4 Pages	
LED Flash	Red, Blue, Green	
Working Life	5 Years (4 Updates per day)	
Battery	2x550mAh	
Changeable Battery	Battery Pack	
Operating Temperature	0 °C to 30 °C	
Operating Humidity	30% to 70%	
Protection Level	IP54	
Certification	ROHS, CE, FCC, MIC	
RF Wireless Communication Parameters	Working Frequency: 2402Mhz to 2480Mhz	System Throughput: Up to 18,000 labels per hour
Included Accessories	TBC	
Optional Accessories	TBC	
Warranty Period	3 Year Warranty	
Technical Support	Lifetime	

-ESL-G-TYPE 2.6"-

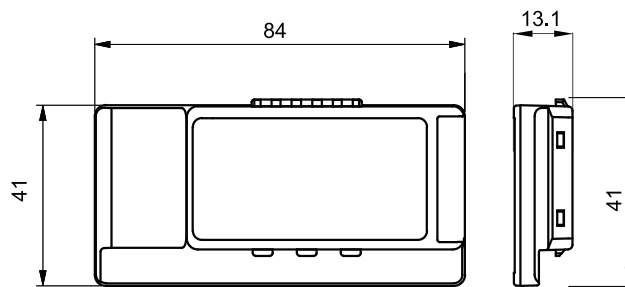

	2.6"	
Unit Size (WxHxD mm)	84x41x13.1	
Display Area (mm)	60.1x30.7	
Resolution	296x152	
Net Weight (g)	43	
Case Colour	White or customised	
DPI	125	
Display Colour	BWR, BWY	
NFC	<p>"N" means the ESL with NFC function.</p> <ol style="list-style-type: none"> 1. Complies with ISO/IEC 14443 TypeA standard 2. Supports NFC NDEF data format with 200 bytes writable memory 3. Communication distance is reachable maximum 10mm 4. Batch update of the same template 	
Multiple Pages	4 Pages	
LED Flash	Red, Blue, Green	
Working Life	5 Years (4 Updates per day)	
Battery	2x550mAh	
Changeable Battery	Battery Pack	
Operating Temperature	0 °C to 30 °C	
Operating Humidity	30% to 70%	
Protection Level	IP54	
Certification	ROHS, CE, FCC, MIC	
RF Wireless Communication Parameters	Working Frequency: 2402Mhz to 2480Mhz	System Throughout: Up to 18,000 labels per hour
Included Accessories	TBC	
Optional Accessories	TBC	
Warranty Period	3 Year Warranty	
Technical Support	Lifetime	

-ESL-G-TYPE 2.9"-

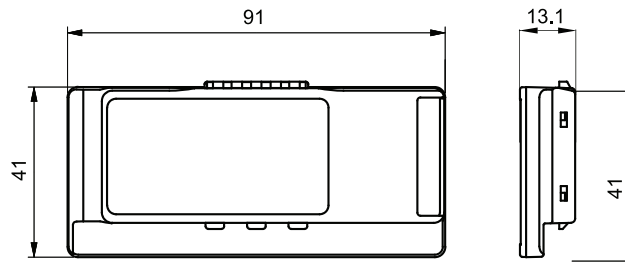

	2.9"	
Unit Size (WxHxD mm)	91x41x13.1	
Display Area (mm)	66.9x29.1	
Resolution	296x128	
Net Weight (g)	21.7	
Case Colour	White or customised	
DPI	112	
Display Colour	BWR, BWY	
NFC	<p>"N" means the ESL with NFC function.</p> <ol style="list-style-type: none"> 1. Complies with ISO/IEC 14443 TypeA standard 2. Supports NFC NDEF data format with 200 bytes writable memory 3. Communication distance is reachable maximum 10mm 4. Batch update of the same template 	
Multiple Pages	4 Pages	
LED Flash	Red, Blue, Green	
Working Life	5 Years (4 Updates per day)	
Battery	2x550mAh	
Changeable Battery	Battery Pack	
Operating Temperature	0 °C to 30 °C	
Operating Humidity	30% to 70%	
Protection Level	IP54	
Certification	ROHS, CE, FCC, MIC	
RF Wireless Communication Parameters	Working Frequency: 2402Mhz to 2480Mhz	System Throughput: Up to 18,000 labels per hour
Included Accessories	TBC	
Optional Accessories	TBC	
Warranty Period	3 Year Warranty	
Technical Support	Lifetime	

-ESL-G-TYPE 4.2”-

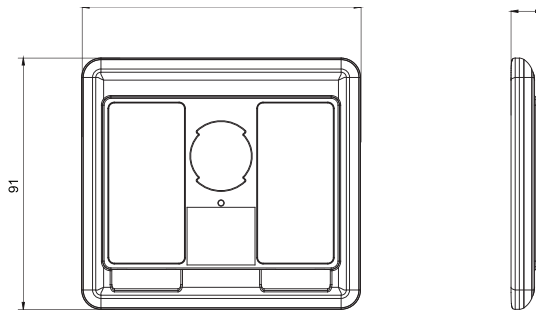

	4.2”	
Unit Size (WxHxD mm)	101x92x11.4	
Display Area (mm)	84.8x63.6	
Resolution	400x300	
Net Weight (g)	102	
Case Colour	White or customised	
DPI	120	
Display Colour	BWR, BWY	
NFC	<p>“N” means the ESL with NFC function.</p> <ol style="list-style-type: none"> 1. Complies with ISO/IEC 14443 TypeA standard 2. Supports NFC NDEF data format with 200 bytes writable memory 3. Communication distance is reachable maximum 10mm 4. Batch update of the same template 	
Multiple Pages	4 Pages	
LED Flash	Red, Blue, Green	
Working Life	5 Years (4 Updates per day)	
Battery	4x550mAh	
Changeable Battery	Battery Pack	
Operating Temperature	0 °C to 30 °C	
Operating Humidity	30% to 70%	
Protection Level	IP65	
Certification	ROHS, CE, FCC, MIC	
RF Wireless Communication Parameters	Working Frequency: 2402Mhz to 2480Mhz	System Throughout: Up to 18,000 labels per hour
Included Accessories	TBC	
Optional Accessories	TBC	
Warranty Period	3 Year Warranty	
Technical Support	Lifetime	

-ESL-G-TYPE 5.8”-

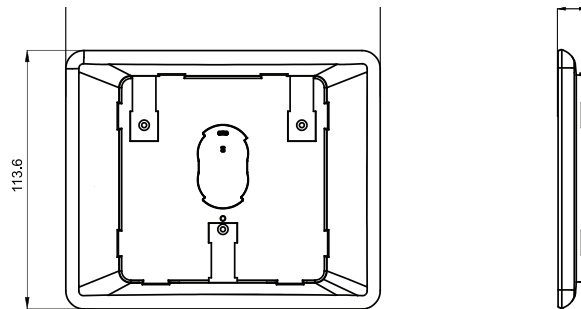

	5.8"	
Unit Size (WxHxD mm)	138.2x113.6x12.3	
Display Area (mm)	118.8x88.2	
Resolution	648x480	
Net Weight (g)	160	
Case Colour	White or customised	
DPI	138	
Display Colour	BWR, BWY	
NFC	<p>"N" means the ESL with NFC function.</p> <ol style="list-style-type: none"> 1. Complies with ISO/IEC 14443 TypeA standard 2. Supports NFC NDEF data format with 200 bytes writable memory 3. Communication distance is reachable maximum 10mm 4. Batch update of the same template 	
Multiple Pages	4 Pages	
LED Flash	Red, Blue, Green	
Working Life	5 Years (4 Updates per day)	
Battery	4x550mAh	
Changeable Battery	Battery Pack	
Operating Temperature	0 °C to 30 °C	
Operating Humidity	30% to 70%	
Protection Level	IP65	
Certification	ROHS, CE, FCC, MIC	
RF Wireless Communication Parameters	Working Frequency: 2402Mhz to 2480Mhz	System Throughput: Up to 18,000 labels per hour
Included Accessories	TBC	
Optional Accessories	TBC	
Warranty Period	3 Year Warranty	
Technical Support	Lifetime	

-ESL-G-TYPE 7.5”-

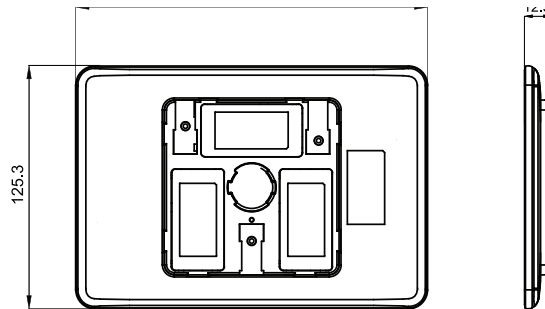

	7.5”	
Unit Size (WxHxD mm)	183x125.3x12.5	
Display Area (mm)	163x98	
Resolution	640x384	
Net Weight (g)	234	
Case Colour	White or customised	
DPI	188	
Display Colour	BWR, BWY	
NFC	<p>“N” means the ESL with NFC function.</p> <ol style="list-style-type: none"> 1. Complies with ISO/IEC 14443 TypeA standard 2. Supports NFC NDEF data format with 200 bytes writable memory 3. Communication distance is reachable maximum 10mm 4. Batch update of the same template 	
Multiple Pages	4 Pages	
LED Flash	Red, Blue, Green	
Working Life	5 Years (4 Updates per day)	
Battery	6x550mAh	
Changeable Battery	Battery Pack	
Operating Temperature	0 °C to 30 °C	
Operating Humidity	30% to 70%	
Protection Level	IP65	
Certification	ROHS, CE, FCC, MIC	
RF Wireless Communication Parameters	Working Frequency: 2402Mhz to 2480Mhz	System Throughput: Up to 18,000 labels per hour
Included Accessories	TBC	
Optional Accessories	TBC	
Warranty Period	3 Year Warranty	
Technical Support	Lifetime	

-ESL-G-TYPE 10.2”-

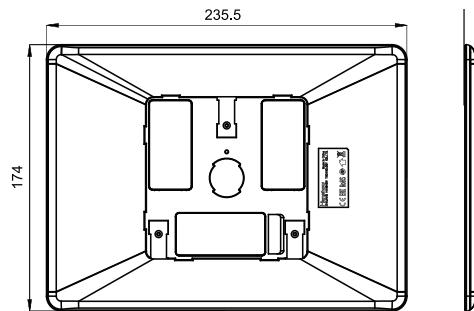

	10.2"	
Unit Size (WxHxD mm)	235.5x174x12.6	
Display Area (mm)	215.5x143.7	
Resolution	960x640	
Net Weight (g)	365	
Case Colour	White or customised	
DPI	113	
Display Colour	BWR, BWY	
NFC	<p>"N" means the ESL with NFC function.</p> <ol style="list-style-type: none"> 1. Complies with ISO/IEC 14443 TypeA standard 2. Supports NFC NDEF data format with 200 bytes writable memory 3. Communication distance is reachable maximum 10mm 4. Batch update of the same template 	
Multiple Pages	4 Pages	
LED Flash	Red, Blue, Green	
Working Life	5 Years (4 Updates per day)	
Battery	6x550mAh	
Changeable Battery	Battery Pack	
Operating Temperature	0 °C to 30 °C	
Operating Humidity	30% to 70%	
Protection Level	IP65	
Certification	ROHS, CE, FCC, MIC	
RF Wireless Communication Parameters	Working Frequency: 2402Mhz to 2480Mhz	System Throughput: Up to 18,000 labels per hour
Included Accessories	TBC	
Optional Accessories	TBC	
Warranty Period	3 Year Warranty	
Technical Support	Lifetime	

-ESL-F-TYPE 2.1"-

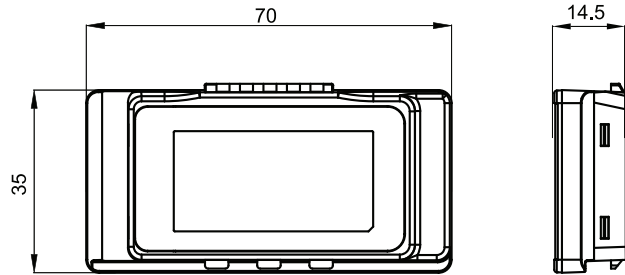

	2.1"	
Unit Size (WxHxD mm)	70x35x14.5	
Display Area (mm)	48.6x23.7	
Resolution	212x104	
Net Weight (g)	37	
Case Colour	Ice Blue	
DPI	111	
Display Colour	BW	
NFC	<p>"N" means the ESL with NFC function.</p> <ol style="list-style-type: none"> 1. Complies with ISO/IEC 14443 TypeA standard 2. Supports NFC NDEF data format with 200 bytes writable memory 3. Communication distance is reachable maximum 10mm 4. Batch update of the same template 	
Multiple Pages	4 Pages	
LED Flash	Red, Blue, Green	
Working Life	5 Years (4 Updates per day)	
Battery	1x950mAh	
Changeable Battery	Battery Pack	
Operating Temperature	-25°C to 0°C	
Storage Temperature	-25°C to 30°C	
Operating Humidity	30% to 70%	
Protection Level	IP67	
Certification	ROHS, CE, FCC, MIC	
RF Wireless Communication Parameters	Working Frequency: 2402Mhz to 2480Mhz	System Throughout: Up to 18,000 labels per hour
Included Accessories	TBC	
Optional Accessories	TBC	
Warranty Period	3 Year Warranty	
Technical Support	Lifetime	

-ESL-F-TYPE 2.6"-

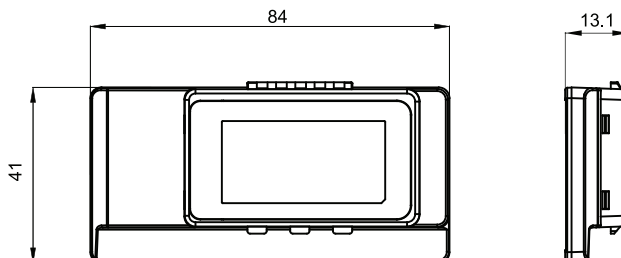

	2.6"	
Unit Size (WxHxD mm)	84x41x13.1	
Display Area (mm)	60.1x30.7	
Resolution	296x152	
Net Weight (g)	36	
Case Colour	Ice Blue	
DPI	125	
Display Colour	BW	
NFC	<p>"N" means the ESL with NFC function.</p> <ol style="list-style-type: none"> 1. Complies with ISO/IEC 14443 TypeA standard 2. Supports NFC NDEF data format with 200 bytes writable memory 3. Communication distance is reachable maximum 10mm 4. Batch update of the same template 	
Multiple Pages	4 Pages	
LED Flash	Red, Blue, Green	
Working Life	5 Years (4 Updates per day)	
Battery	1x950mAh	
Changeable Battery	Battery Pack	
Operating Temperature	-25°C to 0°C	
Storage Temperature	-25°C to 30°C	
Operating Humidity	30% to 70%	
Protection Level	IP67	
Certification	ROHS, CE, FCC, MIC	
RF Wireless Communication Parameters	Working Frequency: 2402Mhz to 2480Mhz	System Throughout: Up to 18,000 labels per hour
Included Accessories	TBC	
Optional Accessories	TBC	
Warranty Period	3 Year Warranty	
Technical Support	Lifetime	

-ESL-P-TYPE 1.54"-

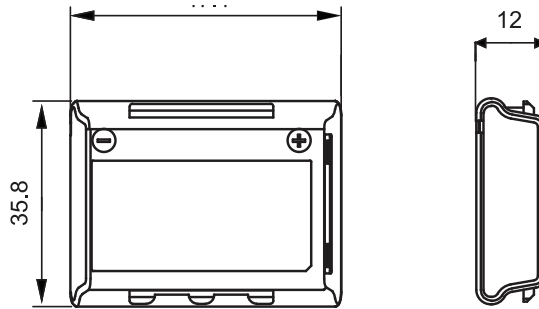

	1.54"	
Unit Size (WxHxD mm)	47.1x35.8x12	
Display Area (mm)	27.6x27.6	
Resolution	200x200	
Net Weight (g)	27	
Case Colour	White/Gray/Black	
DPI	140	
Display Colour	BWR	
NFC	<p>"N" means the ESL with NFC function.</p> <ol style="list-style-type: none"> 1. Complies with ISO/IEC 14443 TypeA standard 2. Supports NFC NDEF data format with 200 bytes writable memory 3. Communication distance is reachable maximum 10mm 4. Batch update of the same template 	
Multiple Pages	4 Pages	
LED Flash	Red, Blue, Green	
Working Life	5 Years (4 Updates per day)	
Battery	1x550mAh	
Changeable Battery	Battery Pack	
Operating Temperature	0 °C to 30 °C	
Operating Humidity	30% to 70%	
Protection Level	IP50	
Certification	ROHS, CE, FCC, MIC	
RF Wireless Communication Parameters	Working Frequency: 2402Mhz to 2480Mhz	System Throughout: Up to 18,000 labels per hour
Included Accessories	TBC	
Optional Accessories	TBC	
Warranty Period	3 Year Warranty	
Technical Support	Lifetime	

-ESL-P-TYPE 2.13"-

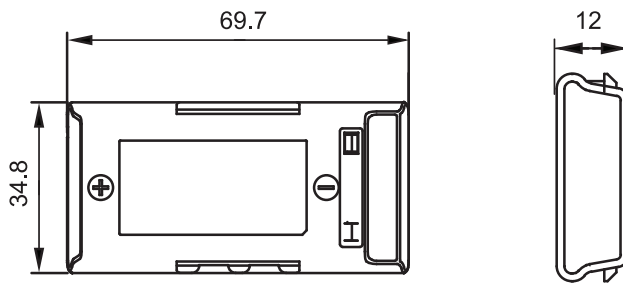

	2.13"	
Unit Size (WxHxD mm)	69.7x34.8x12	
Display Area (mm)	48.6x23.7	
Resolution	250x122	
Net Weight (g)	35	
Case Colour	White/Gray/Black	
DPI	131	
Display Colour	BWR	
NFC	<p>"N" means the ESL with NFC function.</p> <ol style="list-style-type: none"> 1. Complies with ISO/IEC 14443 TypeA standard 2. Supports NFC NDEF data format with 200 bytes writable memory 3. Communication distance is reachable maximum 10mm 4. Batch update of the same template 	
Multiple Pages	4 Pages	
LED Flash	Red, Blue, Green	
Working Life	5 Years (4 Updates per day)	
Battery	1x550mAh	
Changeable Battery	Battery Pack	
Operating Temperature	0 °C to 30 °C	
Operating Humidity	30% to 70%	
Protection Level	IP50	
Certification	ROHS, CE, FCC, MIC	
RF Wireless Communication Parameters	Working Frequency: 2402Mhz to 2480Mhz	System Throughput: Up to 18,000 labels per hour
Included Accessories	TBC	
Optional Accessories	TBC	
Warranty Period	3 Year Warranty	
Technical Support	Lifetime	

-ESL-P-TYPE 2.66"-

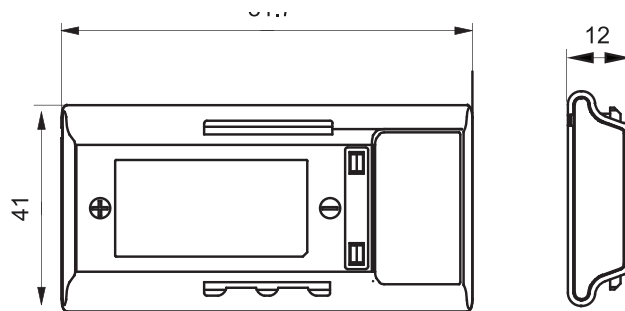

	2.66"	
Unit Size (WxHxD mm)	81.7x41x12	
Display Area (mm)	60.1x30.7	
Resolution	296x152	
Net Weight (g)	41	
Case Colour	White/Gray/Black	
DPI	125	
Display Colour	BWR	
NFC	<p>"N" means the ESL with NFC function.</p> <ol style="list-style-type: none"> 1. Complies with ISO/IEC 14443 TypeA standard 2. Supports NFC NDEF data format with 200 bytes writable memory 3. Communication distance is reachable maximum 10mm 4. Batch update of the same template 	
Multiple Pages	4 Pages	
LED Flash	Red, Blue, Green	
Working Life	5 Years (4 Updates per day)	
Battery	2x550mAh	
Changeable Battery	Battery Pack	
Operating Temperature	0 °C to 30 °C	
Operating Humidity	30% to 70%	
Protection Level	IP50	
Certification	ROHS, CE, FCC, MIC	
RF Wireless Communication Parameters	Working Frequency: 2402Mhz to 2480Mhz	System Throughput: Up to 18,000 labels per hour
Included Accessories	TBC	
Optional Accessories	TBC	
Warranty Period	3 Year Warranty	
Technical Support	Lifetime	

-ESL-P-TYPE 3.7"-

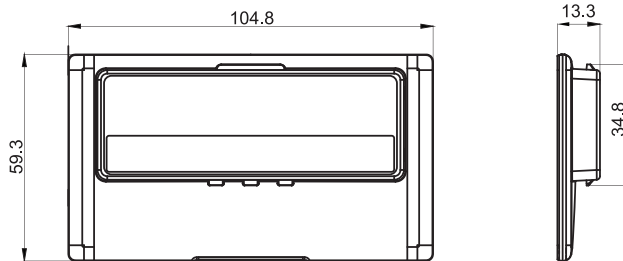

	3.7"	
Unit Size (WxHxD mm)	104.8x59.3x13.3	
Display Area (mm)	81.5x47	
Resolution	416x240	
Net Weight (g)	68.5	
Case Colour	White/Gray/Black	
DPI	130	
Display Colour	BWR	
NFC	<p>"N" means the ESL with NFC function.</p> <ol style="list-style-type: none"> 1. Complies with ISO/IEC 14443 TypeA standard 2. Supports NFC NDEF data format with 200 bytes writable memory 3. Communication distance is reachable maximum 10mm 4. Batch update of the same template 	
Multiple Pages	4 Pages	
LED Flash	Red, Blue, Green	
Working Life	5 Years (4 Updates per day)	
Battery	3x550mAh	
Changeable Battery	Battery Pack	
Operating Temperature	0 °C to 30 °C	
Operating Humidity	30% to 70%	
Protection Level	IP50	
Certification	ROHS, CE, FCC, MIC	
RF Wireless Communication Parameters	Working Frequency: 2402Mhz to 2480Mhz	System Throughout: Up to 18,000 labels per hour
Included Accessories	TBC	
Optional Accessories	TBC	
Warranty Period	3 Year Warranty	
Technical Support	Lifetime	

-ESL-P-TYPE 4.37"-

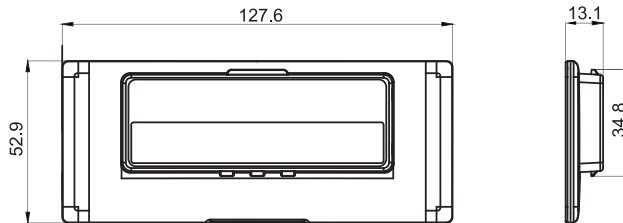

	4.37"	
Unit Size (WxHxD mm)	127.6x52.9x13.1	
Display Area (mm)	104.2x38.2	
Resolution	480x176	
Net Weight (g)	70.3	
Case Colour	White/Gray/Black	
DPI	117	
Display Colour	BWR	
NFC	<p>"N" means the ESL with NFC function.</p> <ol style="list-style-type: none"> 1. Complies with ISO/IEC 14443 TypeA standard 2. Supports NFC NDEF data format with 200 bytes writable memory 3. Communication distance is reachable maximum 10mm 4. Batch update of the same template 	
Multiple Pages	4 Pages	
LED Flash	Red, Blue, Green	
Working Life	5 Years (4 Updates per day)	
Battery	3x550mAh	
Changeable Battery	Battery Pack	
Operating Temperature	0 °C to 30 °C	
Operating Humidity	30% to 70%	
Protection Level	IP50	
Certification	ROHS, CE, FCC, MIC	
RF Wireless Communication Parameters	Working Frequency: 2402Mhz to 2480Mhz	System Throughout: Up to 18,000 labels per hour
Included Accessories	TBC	
Optional Accessories	TBC	
Warranty Period	3 Year Warranty	
Technical Support	Lifetime	

-ESL-P-TYPE 5.84”-

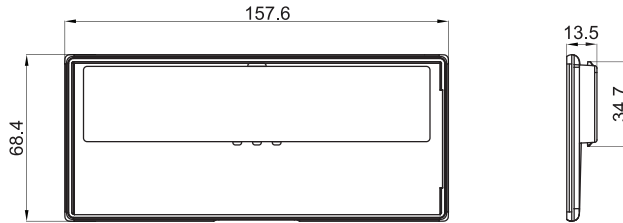

	5.84"	
Unit Size (WxHxD mm)	157.6x68.4x13.5	
Display Area (mm)	140.7x46.9	
Resolution	768x256	
Net Weight (g)	128	
Case Colour	White/Gray/Black	
DPI	138	
Display Colour	BWR	
NFC	<p>"N" means the ESL with NFC function.</p> <ol style="list-style-type: none"> 1. Complies with ISO/IEC 14443 TypeA standard 2. Supports NFC NDEF data format with 200 bytes writable memory 3. Communication distance is reachable maximum 10mm 4. Batch update of the same template 	
Multiple Pages	4 Pages	
LED Flash	Red, Blue, Green	
Working Life	5 Years (4 Updates per day)	
Battery	5x550mAh	
Changeable Battery	Battery Pack	
Operating Temperature	0 °C to 30 °C	
Operating Humidity	30% to 70%	
Protection Level	IP50	
Certification	ROHS, CE, FCC, MIC	
RF Wireless Communication Parameters	Working Frequency: 2402Mhz to 2480Mhz	System Throughput: Up to 18,000 labels per hour
Included Accessories	TBC	
Optional Accessories	TBC	
Warranty Period	3 Year Warranty	
Technical Support	Lifetime	

-ESL-P-TYPE 10.2”-

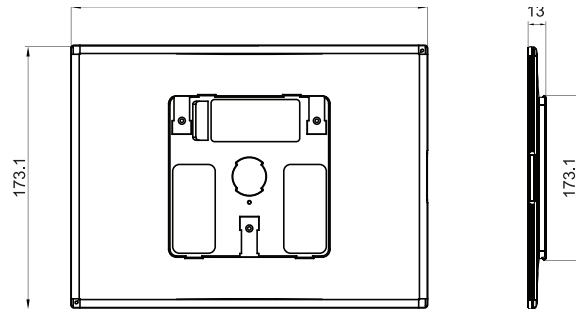

	10.2"	
Unit Size (WxHxD mm)	235.2x173.1x13	
Display Area (mm)	215.5x143.7	
Resolution	960x640	
Net Weight (g)	312.5	
Case Colour	White/Gray/Black	
DPI	113	
Display Colour	BWR	
NFC	<p>"N" means the ESL with NFC function.</p> <ol style="list-style-type: none"> 1. Complies with ISO/IEC 14443 TypeA standard 2. Supports NFC NDEF data format with 200 bytes writable memory 3. Communication distance is reachable maximum 10mm 4. Batch update of the same template 	
Multiple Pages	4 Pages	
LED Flash	Red, Blue, Green	
Working Life	5 Years (4 Updates per day)	
Battery	3x2x550mAh	
Changeable Battery	Battery Pack	
Operating Temperature	0 °C to 30 °C	
Operating Humidity	30% to 70%	
Protection Level	IP50	
Certification	ROHS, CE, FCC, MIC	
RF Wireless Communication Parameters	Working Frequency: 2402Mhz to 2480Mhz	System Throughput: Up to 18,000 labels per hour
Included Accessories	TBC	
Optional Accessories	TBC	
Warranty Period	3 Year Warranty	
Technical Support	Lifetime	





mediagroup

info@media-group.co.uk
digital-screens.co.uk

